

ROTOR

ROTOR 3D CRANKSET. QUICK INSTALLATION GUIDE.

3D ROAD - 130BCD
 3D ROAD - 110BCD
 3D XC3 - 104/104/64 BCD
 3D XC2 - 110/74BCD

Updated 09/2009

Non-Drive Side Assembly
 **DO NOT REMOVE THE BOLT**

Drive Side Assembly
 **DO NOT DISSASSEMBLE**

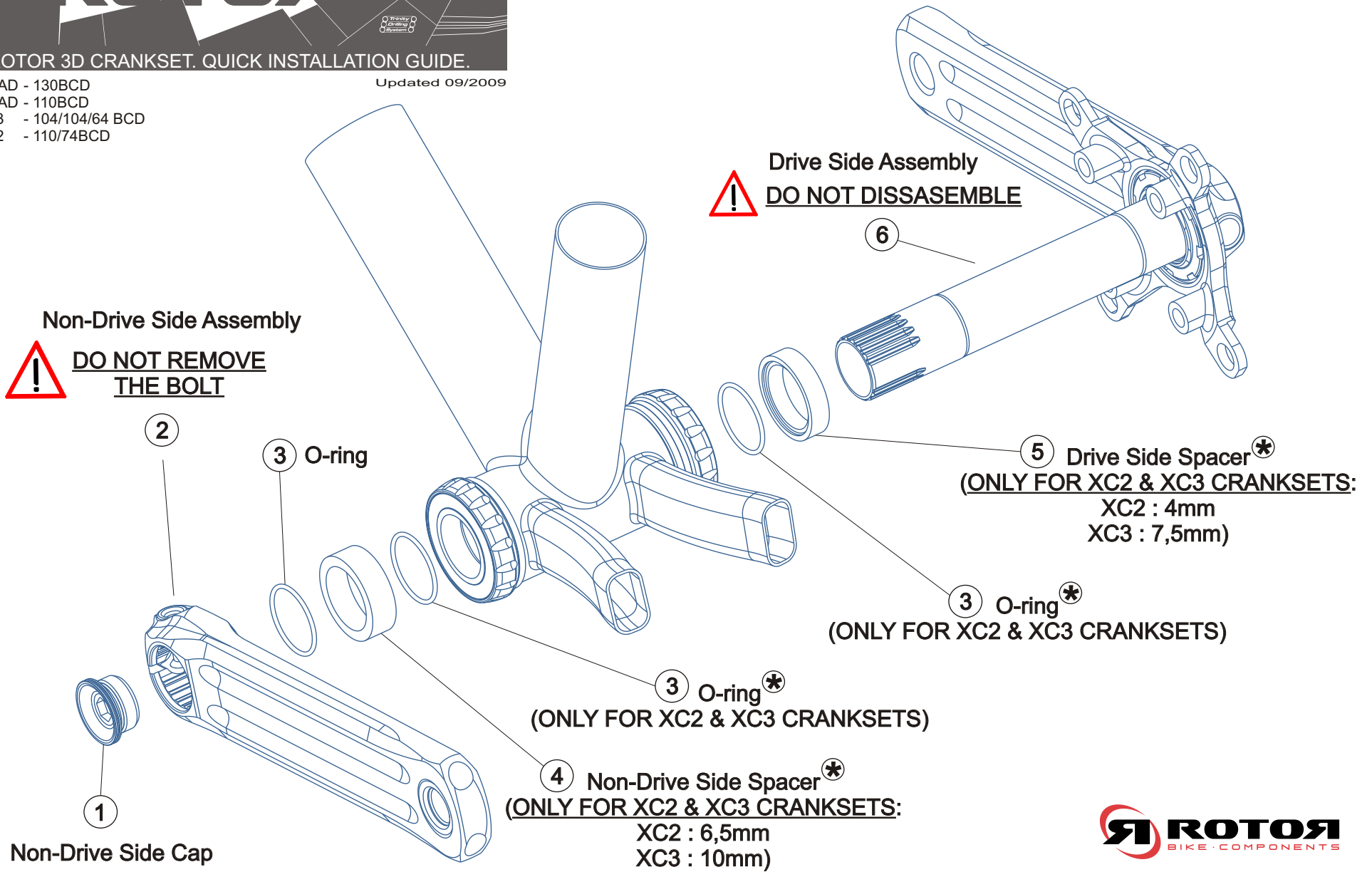

* ROTOR 3D ROAD - 130BCD / 110BCD cranksets do not need spacers, they must be fitted only using one O-ring.

For more information about installation, maintenance and warranty, please visit: www.rotorbike.com
info@rotorbike.com



ROTOR COMPONENTES
 TECNOLÓGICOS SL
 Pol. Ind. Conmar. C/Tajo, Nave 6.
 28864, Ajalvir, Madrid, Spain

#1. Bottom Bracket and Rings Installation.

Read ROTOR SABB or BB1, and Q-RINGS user manuals:

www.rotorbike.com

#2. Remove the Non-Drive Side Assembly.

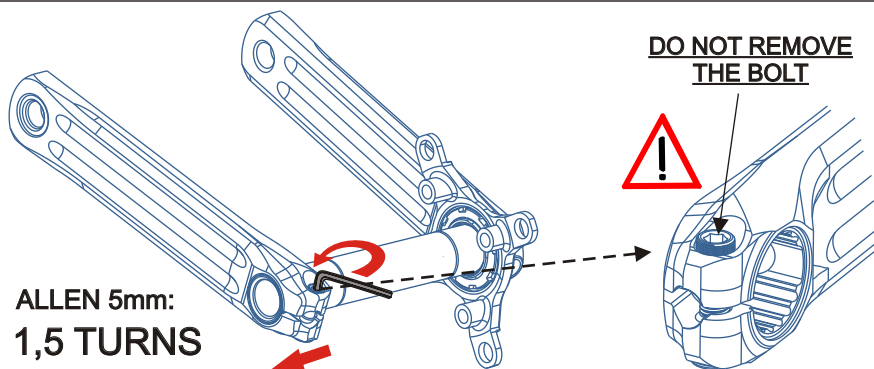

#3. Drive-Side Assembly Installation.

ONLY FOR XC2 & XC3

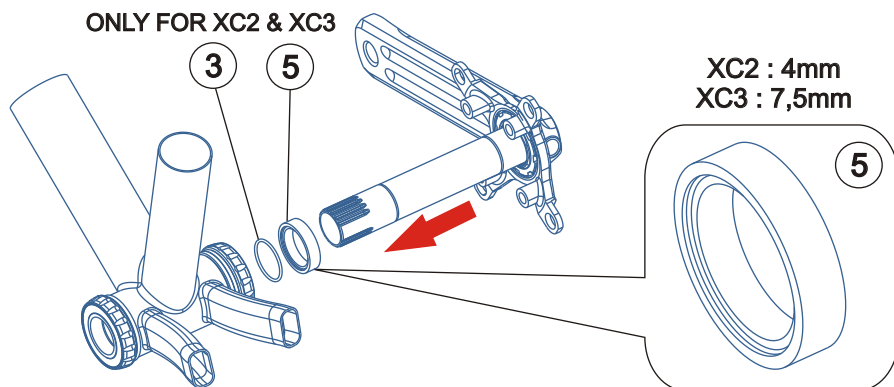

#4. Non-Drive Side Spacer / O-rings Installation.

⊛No spacers with road cranksets, only 1 O-ring.

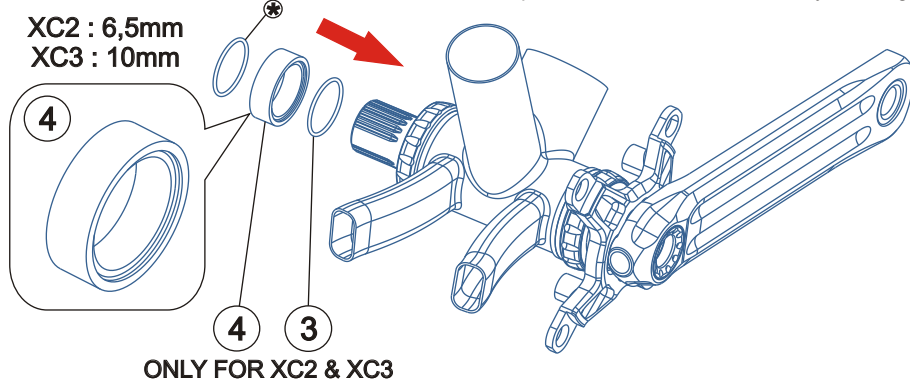

#5. Non-Drive Side Assembly Installation.

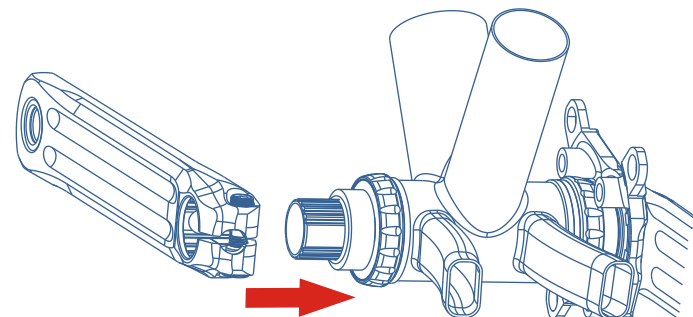

#6. Non-Drive Side Cap installation / preload.

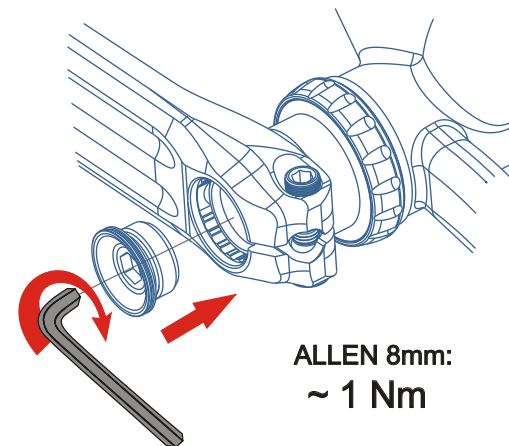

#7. Non-Drive Side Assembly fixing.

